

LITERATURE CITED

1. D. A. Labuntsov, *Teploénergetika*, No. 2, 49-51 (1957).
2. K. D. Voskresenskii, *Izv. Akad. Nauk SSSR, Otd. Tekh. Nauk*, No. 7, 1023-1028 (1948).
3. G. I. Gimbutis, *Mekhanika-14*, Vilnius (1983), pp. 891-896.
4. G. I. Gimbutis and I. Yu. Reklaitis, *Inzh.-Fiz. Zh.*, 46, No. 6, 891-896 (1984).
5. N. V. Zozulya, *Heat Transfer and Heat Modeling* [in Russian], Moscow (1959), pp. 287-297.
6. T. Fujii, H. Uehara, and K. Oda, *Heat Transfer Jpn. Res.*, No. 4, 76-83 (1972).
7. I. I. Gogonin, A. R. Dorokhov, and V. I. Sosunov, *Heat Exchange in Film Condensation of Steam*, SO AN SSSR, Institute of Heat Physics, No. 48, Novosibirsk (1980).
8. I. I. Gogonin, A. R. Dorokhov, V. I. Sosunov, and N. V. Kubysheva, *Heat Exchange and Hydrogasdynamics in Steam Condensation*, Novosibirsk (1979), pp. 368-372.
9. I. I. Gogonin, V. I. Sosunov, S. I. Lazarev, and O. A. Kabov, *Teploénergetika*, No. 3, 17-19 (1983).
10. V. P. Isachenko, *Heat Exchange in Condensation* [in Russian], Moscow (1977).
11. V. I. Naidenov, *Teor. Osn. Khim. Tekhnol.*, 19, No. 5, 622-629 (1985).
12. A. M. Brener, V. I. Naidenov, G. A. Berdalieva, and Sh. M. Moldabekov, *Contemporary Problems of Heat and Mass Exchange in Chemical Technology: Transactions of the International School-Seminar, Part 1*, Minsk (1980), pp. 08-75.

INTENSIFICATION OF HEAT TRANSFER DURING
CONDENSATION BY SWIRLING THE VAPOR FLOW

V. G. Rifert and A. I. Sardak

UDC 536.246:536.424.4

Results of a study are presented and a method is described for calculation of local and mean heat transfer during condensation inside a horizontal pipe with a twisted vapor flow.

It is known that twisting a flow of gas and liquid in pipes is an effective means of intensifying heat transfer. However, until now there have not been any studies of the process of condensation in the twisted flow. It can be assumed that for both a one-phase flow and with twisting of the vapor, an increase in the axial component of the mass velocity ρW of the vapor, i.e., at the phase boundary, will lead to an increase in the velocity of the film and, thus, the heat-transfer coefficient during condensation.

Here, we determined local heat-transfer coefficients α_ϕ in the condensation of pure water vapor at atmospheric pressure in a horizontal pipe with an inside diameter $d_{in} = 18$ mm. We performed the study by using the gradient method of investigating heat transfer [1, 2]. The unit we used was schematized in [1]. It consisted of an electric boiler, steam separator, experimental condenser, auxiliary condenser, condensate measuring vessels, circulating pumps, and the necessary measuring instruments. The experimental condenser consisted of two sections (Fig. 1): a feed section 1 of the length $L = 1.35$ m, and a thick-walled measurement section 2 ($d_e/d_{in} = 4.75$) of the length $L = 0.08$ m. Each section had an independent cooling system. The adiabatic section 3, designed for the provision of a screw swirler in the case of twisting of the flow, was installed after the condensate discharge pipe. A pair of copper-constantin thermocouples 5 were installed in the middle of section 2 near the inside and outside surfaces to measure wall temperature on the thick-walled brass pipe. The thermocouples were separated by an angle $\phi = 45^\circ$ about the perimeter of the pipe.

The flow was twisted by means of a local hexagonal screw-type swirler with an angle of twist $\psi = 45^\circ$, and outside diameter of 18 mm, and a length of 47 mm. The ratio of the area of the outlet section of the twisting section to the overall cross section of the pipe was equal to 0.327 and 0.65 (Fig. 1). The screws had the same pitch.

Before the tests were conducted, the thick-walled measurement section, with a length $l = 0.08$ m, was degreased to eliminate dropwise condensation. The section was scavaged with

Kiev Polytechnic Institute. Translated from *Inzhenerno-Fizicheskii Zhurnal*, Vol. 54, No. 1, pp. 92-98, January, 1988. Original article submitted July 3, 1986.

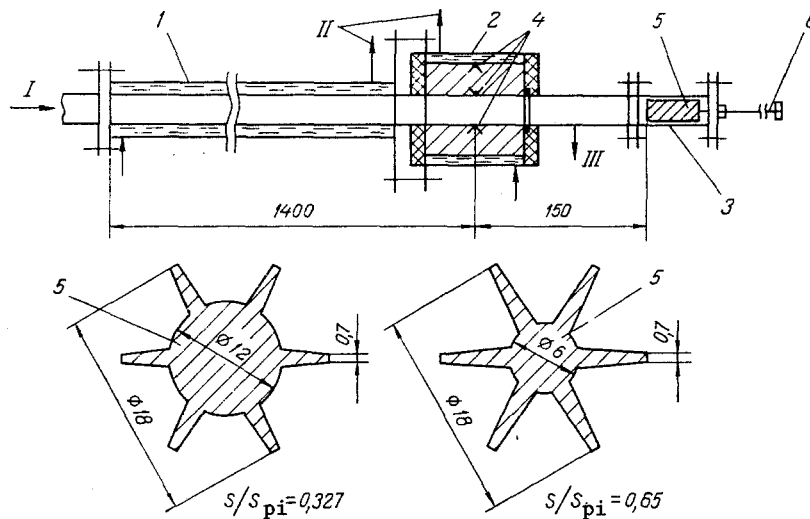

Fig. 1. Diagram of connection of screw swirlers: 1) feed section; 2) measurement section; 3) adiabatic section; 4) wall-temperature measurement section; 5) screw swirler; 6) screw advance rod; I) vapor; II) cooling liquid; III) condensate.

with steam for 5-10 min to remove air. We then established the heat flux on the measurement and feed sections to ensure that the amount of incoming condensate and the vapor velocity in the measurement section were constant.

In the steady-state regime, we used a model Shch-68000 digital voltmeter to measure the emf of the thermocouples embedded in the wall of the thick-walled section. We also determined the discharge of condensate by the volumetric method, the temperature of the vapor and the cooling liquid in the feed and measurement sections, and the vapor pressure and pressure gradient over the entire pipe, including the measurement section, i.e., over a length $L = 1.38$ m.

First we conducted tests in the absence of twisting of the flow. Here, the swirler was located in section 3 (Fig. 1).

We then incrementally advanced the swirler into the experimental condenser from the site where the two-phase flow leaves the thick-walled section. The swirler was moved forward by a rod 3 mm in diameter. The location of the screw was changed from 150 mm in front of the station at which wall temperature was measured in the thick-walled section to 400 mm behind this station.

To reduce the experimental error, all of the experiments were conducted with local temperature heads $\Delta T = T_s - T_{wa}$ exceeding 5°C , which allowed us to determine local values of α_ϕ with a probability > 0.95 .

According to [3], in the local twisting of a one-phase flow, maximum intensification of heat transfer is achieved in the immediate vicinity of the swirler. Heat transfer decreases sharply with increasing distance from the swirler. Due to contraction of the flow at the site of the swirler, the mean velocity of the vapor will be 1.5-2.5 times greater than in an empty pipe. Since the drag coefficient C_t in a twisted flow may simultaneously be several times greater than the value of C_0 for an untwisted flow, then friction at the phase boundary is significantly greater than the force of gravity in the neighborhood of the swirler. This means that the transition to an annular regime of phase flow will occur at considerably lower mean (calculated for the entire cross section of the pipe) vapor velocities in a twisted flow than in the absence of the swirler.

The increase in the friction coefficient in the twisted flow compared to a vapor flow without twisting reduces the effect of the local mean (with respect to ϕ) heat flux q_ϕ on the character of distribution and numerical values of the heat-transfer coefficient α_ϕ (Fig. 2).

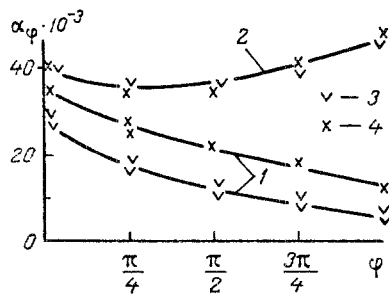

Fig. 2

Fig. 2. Effect of mean heat flux on the local heat-transfer coefficients for $Re_{fi} = 75-80$; $\bar{W}_0 = 24.5 \text{ m/sec}$; 1) axial flow; 2) twisted flow; 3) $\bar{q}_\phi = 10^5 \text{ W/m}^2$; 4) $\bar{q}_\phi = 1.7 \cdot 10^5 \text{ W/m}^2$.

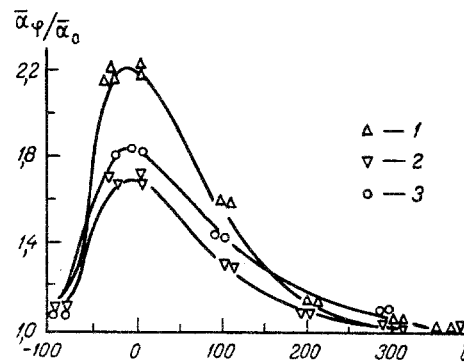

Fig. 3

Fig. 3. Change in the mean heat-transfer coefficients in relation to screw location along the pipe for different \bar{W}_0 and Re_{fi} : 1) $Re_{fi} = 70$, $\bar{W}_0 = 35 \text{ m/sec}$, $\bar{q}_\phi = 10^5 \text{ W/m}^2$; 2) 144, 40, and $2.3 \cdot 10^5$; 3) 70, 17, and 10^5 .

The location of the screw relative to the vertical axis may also affect the change of α_ϕ with respect to ϕ in condensation in a twisted flow. Thus, first we measured the local temperature gradients $\Delta T = T_s - T_{wa}$ for identical \bar{q}_ϕ , \bar{W}_0 , Re_{fi} , and distances l from the wall-temperature measurement section and different rotations of the screw with respect to ϕ .

The results showed that the location of the screw relative to the thermocouples negligibly affects local (with respect to ϕ) values of ΔT_{wa} within the investigated ranges of the regime parameters. The maximum difference in the mean values $\Delta T = T_s - T_{wa}$ (T_{wa} are values of ΔT_{wa} averaged over ϕ) for different rotations of the screw is 10%.

It follows from Fig. 2 that, in contrast to the case of condensation with axial vapor flow [1, 2], in a twisted flow the condensation rate is independent of \bar{q}_ϕ . This is because friction at the phase boundary is affected mainly by the tangential and axial components of vapor velocity, rather than the normal component connected with transverse mass flow.

An increase in the axial velocity of the vapor \bar{W}_0 is accompanied by an increase in the local heat-transfer coefficients on all sections of the pipe perimeter. The presence of the circumferential component of vapor velocity after the screw leads to more rapid equalization of α_ϕ and the thickness of the condensate film with respect to ϕ than in the absence of flow twisting. However, at low \bar{W}_0 , the average values of α_ϕ during condensation are the same in both cases.

Figure 3 shows the effect of the location of the screw on mean values $\bar{\alpha}_\phi$ with different \bar{W}_0 and Re_{fi} . The maximum of $\bar{\alpha}_\phi$ is reached when the screw is located in front of the section with the thermocouples. As the screw is removed from this section, heat transfer decreases sharply and twisting has almost no effect at the distance $l = 200-300 \text{ mm} = 10-15d$.

Twisting of the vapor flow significantly increases friction.

As shown by Fig. 4, the effect of the screw on $\Delta P = f(l)$ extends over a distance of about 0.6-0.7 m, i.e., nearly twice the distance over which twisting has a significant effect on heat transfer (see Fig. 3). Friction is increased roughly fourfold over the entire control section of a pipe of the length $L = 1.45 \text{ m}$.

Since twisting of the flow has a major effect on friction, then the pressure loss due to acceleration occurring during condensation will be negligibly small for a twisted flow compared to the overall value ΔP . When comparing ΔP for a twisted flow with and without condensation, it must be considered that in the case of condensation, an increase in the distance of the screw from the outlet is accompanied by an increase in vapor velocity \bar{W}_0 and, thus, an increase in additional pressure losses due to flow-twisting (Fig. 4). It is therefore necessary to select regimes for different l for which the velocity \bar{W}_0 ahead of the screw will always be the same and will be equal to \bar{W}_0 for an adiabatic flow. Analysis of the data shows that the values of ΔP with condensation and with adiabatic vapor flow in a pipe with a screw are identical.

TABLE 1. Analysis of Experimental Data on Condensation in a Twisted Flow

\bar{W}_0	Re_{fi}	W_{cr}	$\bar{W} = \bar{W}_0 / \bar{W}_{cr}$	$\left(\frac{\bar{\alpha}_t}{\alpha_0}\right)_{max}$
36	16	5,4	6,7	2,6
35	70	6,8	5,15	2,2
17	70	6,1	2,8	1,65
38	144	7,8	4,7	1,9

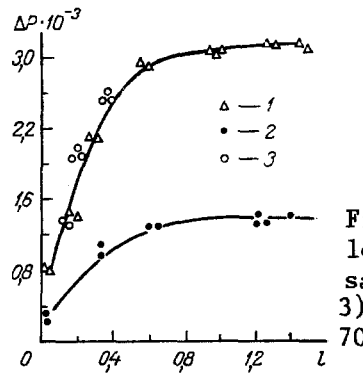

Fig. 4. Dependence of the pressure loss ΔP on l : 1-2) without condensation, $\bar{W}_0 = 33$ (1) and 20 m/sec (2); 3) with condensation, $\bar{W}_0 = 30$ sec; $Re_{fi} = 70$

Comparison of experimental data on heat transfer for condensation in a twisted flow and established laws for heat transfer in a one-phase twisted flow 3 shows both similarities and differences in these processes.

As for a one-phase flow, a maximum in the intensification of heat transfer $\bar{\alpha}_t / \bar{\alpha}_0$ is seen in the neighborhood of the screw, and the heat-transfer rate decreases sharply with increasing distance from the screw. However, the value of $\bar{\alpha}_t / \bar{\alpha}_0$ at the mean velocity of the main flow is greater with condensation than in the one-phase flow. The rate of heat transfer is also influenced by the Reynolds number Re_{fi} . An increase in the latter is accompanied by a decrease in $\bar{\alpha}_t$. The above features can be explained by the presence of the condensate film on the channel wall.

Heat transfer during condensation depends to a considerable extent on the interaction of the phases at the phase boundary. This interaction is intensified with an increase in vapor velocity \bar{W}_0 and heat flux q_ϕ , since both of these parameters affect the friction coefficient C_f at the phase boundary [4].

When the vapor flow is twisted, rotational motion of the main flow makes the main contribution to the pressure losses. As in the flow of phases without twisting, the presence of the condensate film should not effect friction. Due to friction at the phase boundary, the rate of twisting decays rapidly at this site. Thus, the heat-transfer coefficient decreases considerably more rapidly than does ΔP with increasing distance of the screw from the measurement section (see Figs. 3 and 4).

The reduction in the rate of heat transfer during condensation in a twisted flow with an increase in Re_{fi} is evidence that mainly laminar flow continues in the condensate film. Thus, it can be suggested that the mechanism by which flow-twisting affects the heat-transfer rate in film condensation is an increase in friction at the phase boundary and a consequent reduction in the thickness of the condensate film. In the region of the pipe surface near the screw, the increase in the velocity of the axial flow resulting from the reduction in the cross section of the channel also has a significant effect.

Thus, to calculate heat transfer for the case of condensation in a twisted vapor flow, it is necessary to know the friction coefficient at the phase boundary.

Analysis of Fig. 4 leads to the conclusion that the pressure losses ΔP_t in a twisted vapor flow are greater than ΔP_0 in an axial flow by a factor of about four for both $\bar{W}_0 = 20$ m/sec and for $\bar{W}_0 = 33$ m/sec. Here, ΔP_t for $\bar{W}_0 = 33$ m/sec is greater than ΔP_t for $\bar{W}_0 = 20$ m/sec by a factor of 2.3, i.e., a factor of $(33/20)^2$. This result suggests that swirling of the vapor increases ΔP , regardless of the vapor velocity, due to the effect of the nominal mean local resistance $\xi_t = 4\xi_0$ for the axial flow. Thus, we take a friction coefficient

$C_{ft} = 4C_{f0}$ in the calculation of ΔP_t in the twisted vapor flow, where C_{f0} is the friction coefficient for the axial flow at the same mean vapor velocities $\bar{W}_{v,0}$. Then the mean heat transfer α_t for condensation in a twisted flow can be calculated as follows.

We will determine the vapor velocity \bar{W}_{cr} above which interphase friction begins to affect the hydrodynamics of the condensate film and heat transfer during condensation. In accordance with the method proposed in [2, 4], this regime corresponds to the condition

$$C_{ft} Fr > 0,86 Re_{fi}^{1/3}. \quad (1)$$

Here, C_{ft} is the friction coefficient in the twisted vapor flow.

For mean values of Re_{fi} and \bar{W}_0 , we determine W_{cr} from (1) and we find the ratio \bar{W}_0/\bar{W}_{cr} (see Table 1). Table 1 also shows the maximum values of heat-transfer intensification $(\bar{\alpha}_t/\bar{\alpha}_0)_{max}$ obtained from Fig. 3.

We then construct the relation $(\bar{\alpha}_t/\bar{\alpha}_0)_{max} = f(\bar{W}_0/\bar{W}_{cr})$ and we obtain

$$\left(\frac{\bar{\alpha}_t}{\bar{\alpha}_0}\right)_{max} = \left(\frac{\bar{W}_0}{W_{cr}}\right)^{0,5}. \quad (2)$$

Twisting of the vapor flow ceases to affect mean heat transfer for different Re_{fi} and \bar{W}_0 at nearly the same values of l/d (Fig. 4), which is evidence of the steeper drop in $\bar{\alpha}_t/\bar{\alpha}_0$ with an increase in l/d at large $(\bar{\alpha}_t/\bar{\alpha}_0)_{max}$.

Analysis of the experimental data on $\bar{\alpha}_t/\bar{\alpha}_0 = f(l/d)$ (Fig. 4) yielded the following theoretical relation:

$$\frac{\bar{\alpha}_t}{\bar{\alpha}_0} = \left(\frac{\bar{\alpha}_t}{\bar{\alpha}_0}\right)_{max} - a \frac{l}{d} + b \left(\frac{l}{d}\right)^2, \quad (3)$$

where

$$a = 0,74 \frac{\bar{W}_0}{W_{cr}}; \quad b = 1,67 \cdot 10^{-3} \left(\frac{\bar{W}_0}{W_{cr}}\right)^{0,7}.$$

The proposed method of calculating heat transfer in condensation in a twisted flow is approximate, since it is based on a limited amount of experimental data. More reliable relations for calculating α_t can be obtained after performing experiments at low pressure, on other substances, and with different methods of twisting the vapor flow and different swirler designs.

However, it follows even from the data presented here that twisting of the vapor flow is a promising method of intensifying heat transfer during condensation if the vapor velocity is sufficiently high and there are no special restrictions on friction.

The installation of local swirlers after $l/d = 10-15$ will make it possible to increase the average heat-transfer coefficient for the pipe by a factor of 1.5-1.8 compared to an untwisted flow.

NOTATION

α , heat-transfer coefficient, $W/(m^2 \cdot K)$; q , heat flux, W/m^2 ; r , heat of vaporization, kJ/kg ; P , pressure, N/m^2 ; T , t , ambient temperature, K ; W , velocity of medium, m/sec ; ρ , density of medium, kg/m^3 ; g , acceleration due to gravity, m/sec^2 ; L , l , length of pipe, m ; d , diameter of pipe, m ; ν , kinematic viscosity, m^2/sec ; C_f , vapor friction coefficient on the liquid film; ϕ , angular coordinate; ψ , angle of twist. Dimensionless complexes: $Re_{fi} = qL/(r\mu)$; $Fr = \rho_v(\rho_q - \rho_r)W_v^2/[\rho_q^2(\nu_{qg})^{2/3}]$. Indices: v , vapor flow; q , liquid; fi , film; in , internal; t , twisted; 0 , axial; wa , wall; cr , critical; Δ , difference; s , saturation.

LITERATURE CITED

1. A. I. Sardak, V. G. Rifert, and A. N. Tobilevich, *Teploenergetika*, No. 8, 59-62 (1984).
2. V. G. Rifert, A. I. Sardak, and A. N. Tobilevich, *Izv. Akad. Nauk SSSR, Energ. Transp.*, No. 4, 101-109 (1985).
3. V. K. Shchukin, *Heat Transfer and Hydraulics of Internal Flows in a Gravitational Field* [in Russian], Moscow (1970).
4. G. G. Chernyi, *Dokl. Akad. Nauk SSSR*, 101, No. 1, 39-42 (1955).